

KEOFITT® STERILE SAMPLING BAG™ (PAT.PEND.)

ITEM NO. 112000

GENERAL



The Keofitt Sterile Sampling Bag is a sterile, pre-irradiated product supplied in a sealed PE-bag. The product is to be removed from its sterile bag only just before use.

The sterile condition and the closed fluid path enables the user to extract liquid samples from the process line greatly reducing the risk of contaminating the sample from airborne contaminants in the environment compared to using traditional sample recipients.

The Keofitt Sterile Sampling Bag is the ultimate sampling bag solution based on Keofitt's renowned high quality and ultra hygienic sampling valve design.



The Sterile Sampling Bag is intended for collecting and easy storage of samples for chemical analysis. For microbiological samples the Aseptic Sampling Bag is recommended.



The Sterile Sampling Bag is a single-use product.

The product to be sampled should have a maximum viscosity of 1000 cP and should not contain particles larger than 3 mm in diameter. Products with somewhat higher viscosity may be sampled, only will it take longer.

FEATURES

- Single-use product
- Supplied sterilized by Gamma-irradiation in sealed outer PE bag
- Keofitt W9 quick connect (mini sanitary clamp connection also available)
- Pinch clamp to seal sample in bag
- Secondary port with septum for extracting a sample of the sample or for injecting a substance into the sample. Needle max. $\varnothing 0.8\text{mm}$ and max. 5 penetrations. Secondary port also fitted with luer lock fittings (male and female) for secure and sterile connection to relevant equipment in a Laminar Air Flow (LAF) bench.



TECHNICAL DATA

SAMPLING/FILLING:

Allow the bag to be filled by slowly opening the sampling valve and leave it open until required sample volume is obtained. Do never exceed the nominal volume of the bag, as it will eventually burst (safety margin = approx. 3 x nominal volume).

STERILITY:

The sampling bag's fluid path has been validated according to the AAMI TIR 33 with a log-6 Sterility Assurance Level (SAL)

SAMPLE TEMPERATURE:

Up to 90°C (194°F) sample temperature provided delicate handling, support in a tray and leave for cooling to below 60°C (140°F) before further handling

STORAGE AND SHELF LIFE:

The sampling bags are individually packed in a sealed PE bag and delivered in a carton box with a PE liner containing 50 pieces. Shelf life is 3 years following product date printed on the carton box.

Store in original packaging at 50 – 94°F (10 – 34°C) and less than 80% humidity

CERTIFICATES:

Each delivery may be accompanied with a Certificate of Conformity (CoC) covering Sterility, Product conformity, Gamma Irradiation, GMP, FDA regulations 21 CFR part 820, ISO 13485:2003 Quality Standards etc.

For the bag film in constant contact with the sample the CoC covers USP 88 Class VI Biocompatibility, USP 87 Cytotoxicity test, Physicochemical test for Plastic USP 661, Endotoxine test (USP 85) and Extractables test.

SIZES:

The sampling bags are available in the following sizes (part number): 500 ml (110500), 1000 ml (111000) & 2000 ml (112000)

Pos.	Part Name	Material
1	Tube fitting	PC
2	Quick coupling ring	PP
3	Pinch Clamp	PP
4	Tube	Silicone
5	Luer Cap (septum)	ABS/PC/Polyisoprene (septum) Compliant with ISO-594. Latex free.
6	Sampling Bag	178 µm co-extruded laminated LLDPE/EVOH/PA for high barrier properties. See page 2 for further information.

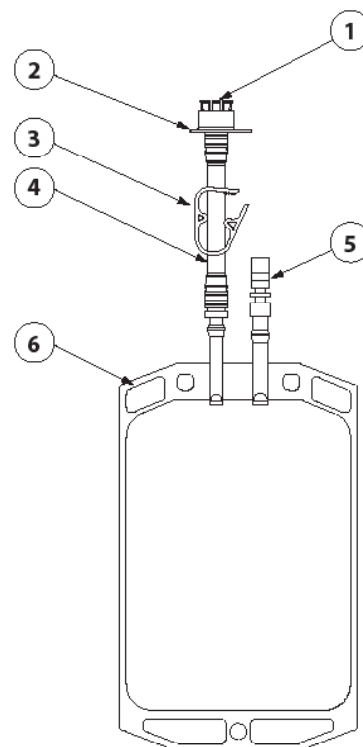

FILM CHARACTERISTICS

POLYETHYLENE SINGLE USE CONTAINER

The bag film is a 5 layer 7 mil/ 178 μm co-extrusion film which provides barrier and durability.



BIOCOMPATIBILITY

USP Acute Systemic Injection Test	Pass	USP <88>
USP Intracutaneous Injection Test	Pass	USP <88>
USP Intramuscular Implantation Test	Pass	USP <88>
USP MEM Elution Method	Non Cytotoxic	USP <87>
Physiochemical Test for Plastics	Pass	USP <661>

PHYSICAL DATA

Water Vapor Transmission Rate	($\text{g}/\text{m}^2/24\text{hrs}$)	0.68	ASTM F-1249
	($\text{g}/100\text{in}^2/24\text{hrs}$)	0.044	
Carbon Dioxide Transmission Rate	($\text{cc}/\text{m}^2/24\text{hrs}$)	2.25	ASTM F-2478
	($\text{cc}/100\text{in}^2/24\text{hrs}$)	0.145	
Oxygen Transmission Rate	($\text{cc}/\text{m}^2/24\text{hrs}$)	4.31	ASTM D-3985
	($\text{cc}/100\text{in}^2/24\text{hrs}$)	0.278	

	Average Force	Average MOE	Average Elongation	
Tensile	13.98 kg 30.79 lbs	3565 bar 51670 psi	611%	ASTM D 882-02
	Min force	Average Force	Max Force	
Tear Resistance	2.21 kg 4.86 lbs	2.36 kg 5.20 lbs	2.47 kg 5.45 lbs	ASTM D1004-07
Puncture Resistance	6.31 kg 13.89 lbs	6.94 kg 15.29 lbs	7.77 kg 17.12 lbs	FTMS 101C

This film is Class VI, non-animal origin, and is supported by a complete testing/documentation package.